

Installation Guide

BSM-MB15

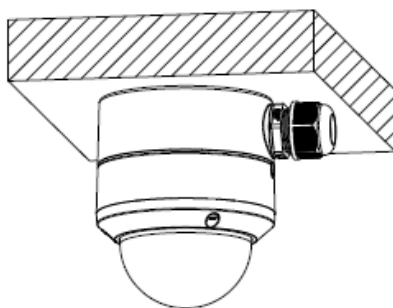

1. Outside dimensions

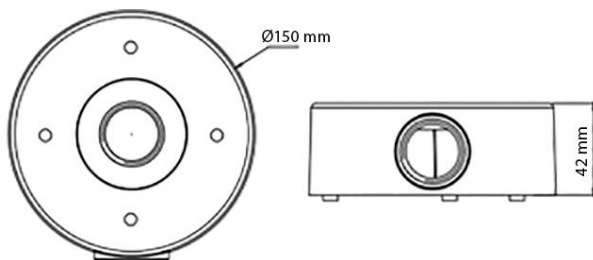
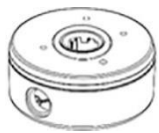
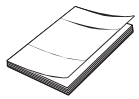

2. List of mounting accessories**Junction box****waterproof plug****Installation Guide****Self-tapping screws****Dowels****Drill template stencil paper****set screws**

3. Installation tool list

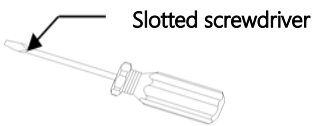
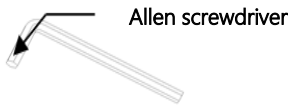
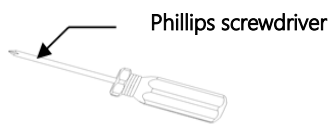
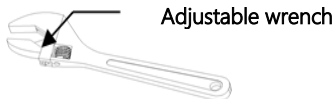

4. Equipment installation

- 1 Fixate the drill template stencil paper on the wall or ceiling, drill 4 expansion screw holes, and hammer the dowels for the self-tapping screws into the holes as shown.

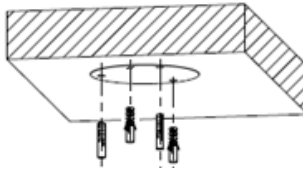

- 2 Take the cable box base, align the 4 screws with the holes, and screw them in to lock the box in position, pass the connecting wires through the waterproof plug and tighten the waterproof plug to the bottom cover as shown in the image below.

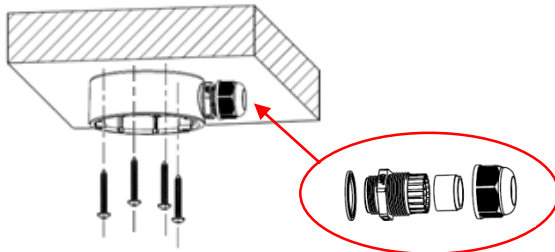

- 3 Unscrew the screws on the dome cover of the camera, remove the transparent cover, lock the base of the camera to the top cover of the cable box, and then align the cameras cable hole with the one of the box. Then tighten the screws on the top cover of the camera by aligning it with the screw holes on the base of the cable box, as shown using the 4 set screws.

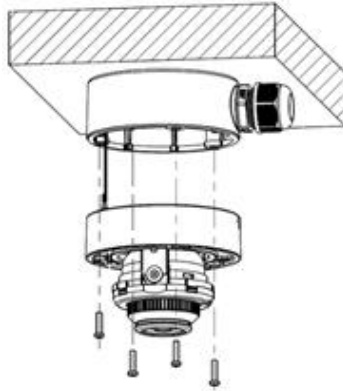

- 4 Lock the dome cover of the camera to the camera base with its corresponding 3 screws, the installation is complete.

